

MYERS® MWS5 Series

Cast Iron Submersible Sewage Pumps

SPECIFICATIONS

Applications	Sewage, Effluent and Wastewater Removal and Transfer, Sump Drainage, Dewatering, Flood Control	
Capacities	130 GPM	492 LPM
Shut-off head	18'	5.5 m
Operation:		
Tethered: On	16"	406.4 mm
Off	7"	177.8 mm
Solids handling	2"	50.8 mm
Intermittent liquid temp	130°F	54.4°C
Motor	1/2 HP, 1550 RPM, 115 Volt or 230 Volt, single-phase, 60 Hz. Oil-filled. Built-in thermal overload protection with automatic reset.	
Acceptable pH range	5-9	
Shaft seal	Type 6A Carbon and Ceramic	
Motor housing	Cast Iron	
Volute case	Cast iron	
Impeller	Vortex reinforced Noryl® with brass threaded insert	
Power cord	10' or 20' water resistant 16-3 SJTW-A/SJTW with integrally grounded three-prong plug	
Discharge, NPT	2"	



3 YEAR
WARRANTY



FEATURES

- Solids Handling – 2" spherical capabilities.
- Overload Protection – Built-in thermal overload with automatic reset.
- Bearing and Mechanical Seal – Permanently lubricated for long life.
- Stainless Steel Hardware – Allows for easy disassembly after extended service.
- Serviceability – Heavy-duty lift-out ring.
- Controls – Standard controls available for automatic operation.
- Cord Design – In-field replaceable 50' cord available, 115 volt only.

ORDERING INFORMATION

Catalog Number	HP	Maximum Load Amps	Volts	Phase/Cycles	Cord Length	Mechanical Switch Type	Switch Setting	
							On	Off
MWS550110M	1/2	13.0	115	1/60	10'	Manual	-	-
MWS550110T						Tethered	16"	7"
MWS550120M					20'	Manual	-	-
MWS550120T						Tethered	16"	7"

Noryl® is a registered trademark of General Electric Co.
Specifications are subject to change without notice.

MYERS[®] MWS5 Series

Cast Iron Submersible Sewage Pumps

OUTLINE DIMENSIONS

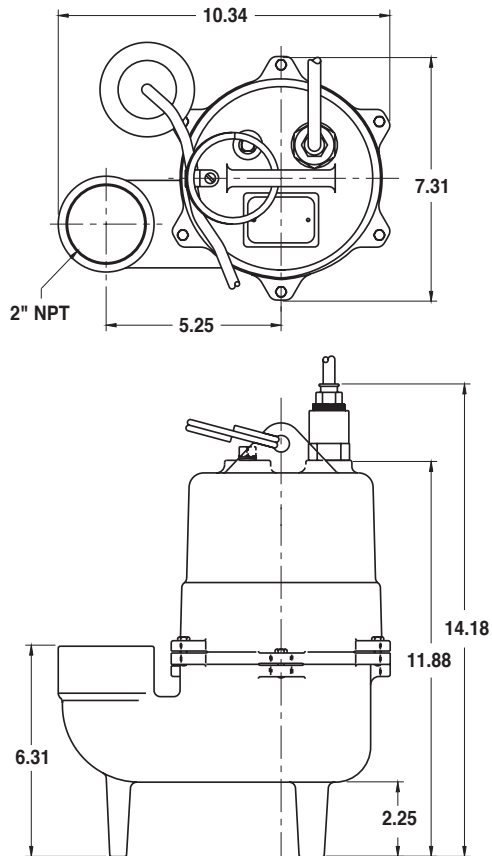

Dimensions (in inches) are for estimating purposes only.

PUMP PERFORMANCE

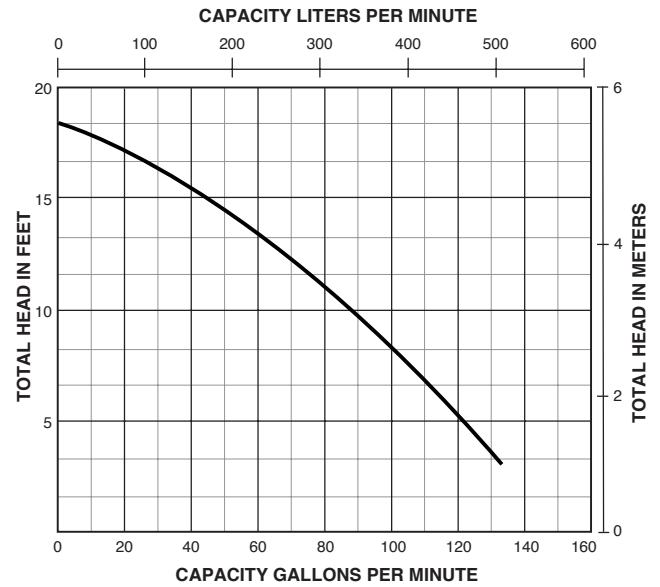

USA
293 WRIGHT STREET, DELAVAN, WI 53115 WWW.FEMYERS.COM
PH: 888-987-8677 ORDERS FAX: 800-426-9446

CANADA
490 PINEBUSH ROAD, UNIT 4, CAMBRIDGE, ONTARIO, N1T 0A5
PH: 800-363-7867 FAX: 888-606-5484

Because we are continuously improving our products and services, Pentair reserves the right to change specifications without prior notice.